

Physical Quantities

1. A capacitor of capacitance C is connected across a strip of conductive paper.

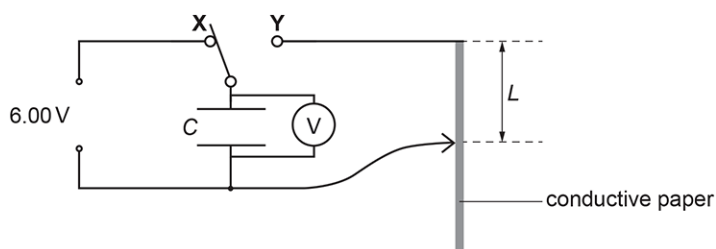

The switch is moved from X to Y, and the time t for the potential difference across the capacitor to halve is measured.

The time t is given by the expression

$$t = (Ck \ln 2) \times L$$

where k is the resistance of the conductive paper per unit length and L is the length of the conductive paper.

The value of C is 1.2×10^{-3} F.

In an experiment, L is changed and t measured.

The data points are plotted on a t against L grid as shown below.

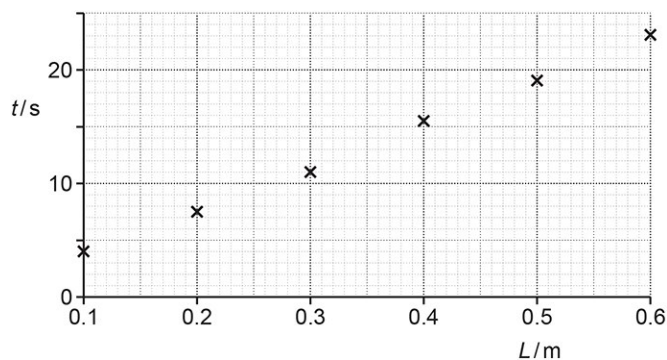

Draw a straight line of best fit through the data points, and use the gradient of this line to determine k .

$k = \dots\dots\dots \Omega \text{ m}^{-1}$ [4]

2.1 Physical Quantities

2 (a). A student is investigating stationary waves in the air column inside a tube, using the apparatus shown in **Fig. 5.1**.

The loudspeaker emits sound of frequency f and wavelength λ . The tube is initially fully immersed in the water. The student then slowly raises the tube until the oscilloscope trace shows its first maximum. A stationary wave of fundamental frequency f is produced in the air column. When this occurs, the student measures the length l of the tube above the water level.

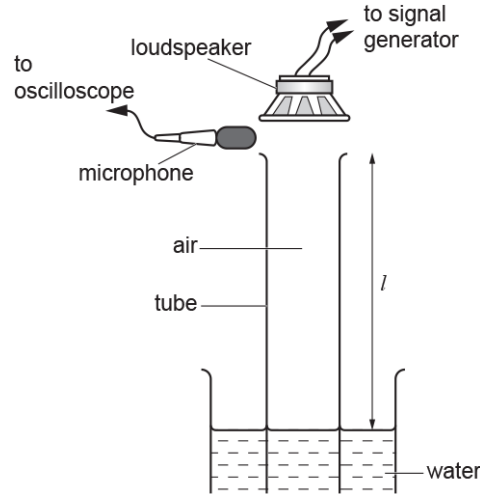
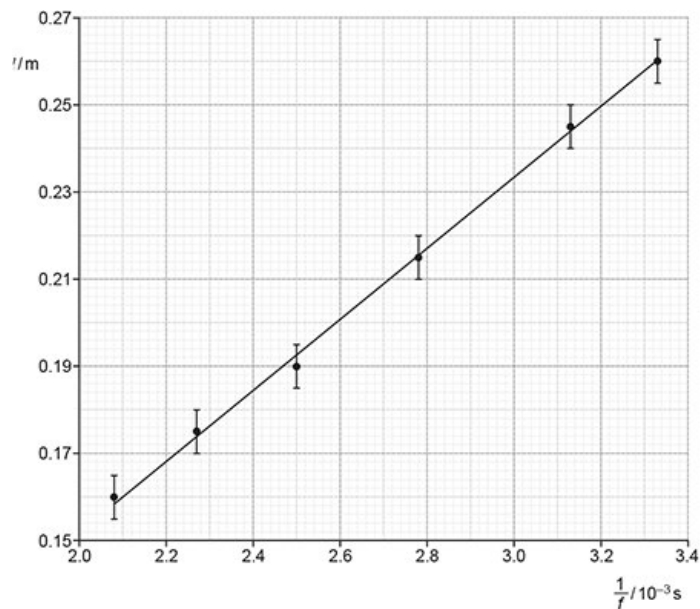

Fig. 5.1

Theory suggests that f and l are related by the equation $4(l + k) = \frac{v}{f}$, where v is the speed of sound in air and k is a constant.

The student measures corresponding values of l and f and plots a graph of l against $\frac{1}{f}$.

The data points, error bars and the line of best fit drawn by the student are shown in the graph below.



- i. Show that the line of best fit has gradient $= \frac{v}{4}$ and y-intercept $= -k$.

2.1 Physical Quantities

- ii. Calculate v from the gradient of the line of best fit.

$$v = \dots\dots\dots \text{m s}^{-1} \quad [3]$$

(b). The experiment is repeated using the same tube and an unlabelled tuning fork, as shown in Fig. 5.2. The distance l is measured as 22 cm.

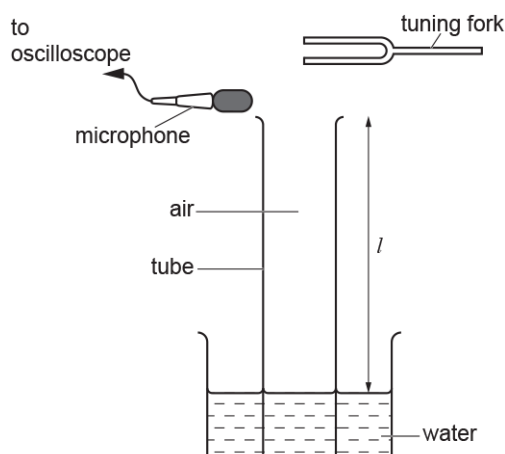

Fig. 5.2

The frequency of the vibrating tuning fork is F .

- i. Use the line of best fit on the graph to estimate F .

$$F = \dots\dots\dots \text{Hz} \quad [2]$$

- ii. The percentage uncertainty in the value of F can be written as $100 \frac{\Delta F}{F}$ where ΔF is the absolute uncertainty in F .

Use the rules for combining uncertainties to write an expression for the percentage uncertainty in the value of F in terms of v and its absolute uncertainty Δv , l and its absolute uncertainty Δl and k and its absolute uncertainty Δk .

2.1 Physical Quantities

3 (a). The London Eye, shown rotating anticlockwise in **Fig. 6.1**, is a giant wheel which rotates slowly at a constant speed.

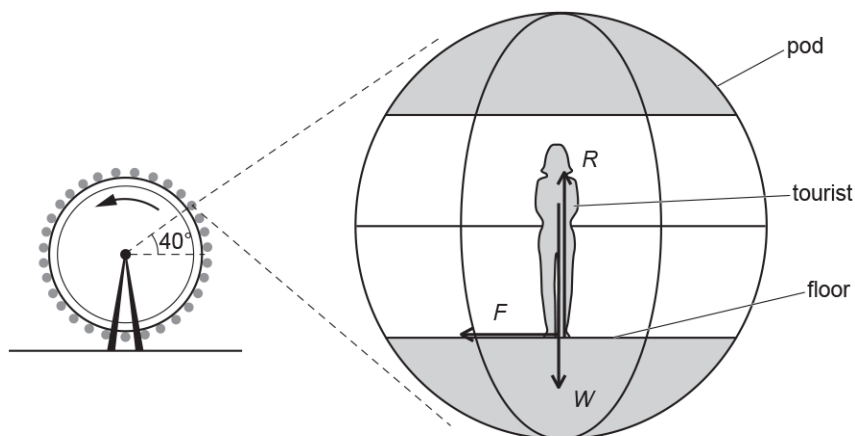

Fig. 6.1

Fig. 6.2

Tourists stand in pods around the circumference of the wheel.

The floor remains horizontal at all times.

At time $t = 0$, a tourist who has a weight W of 650 N enters a pod at the bottom of the wheel.

Fig. 6.2 shows the forces acting on the tourist at a later time, when the angle between the pod's position and the centre of the wheel is 40° above the horizontal. R is the normal contact force and F is friction.

The resultant upward force ($R - W$) on the tourist changes during the 30 minutes of the rotation of the London Eye as shown in **Fig. 6.3**.

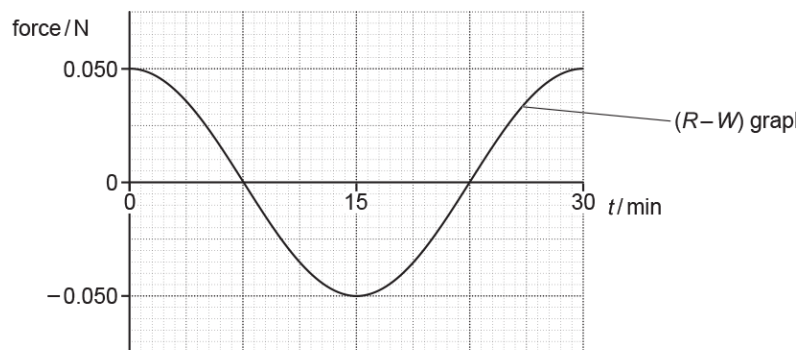

Fig. 6.3

Explain how the graph in **Fig. 6.3** shows that the magnitude of the centripetal force on the tourist during the rotation is 0.050 N.

[1]

2.1 Physical Quantities

(b).

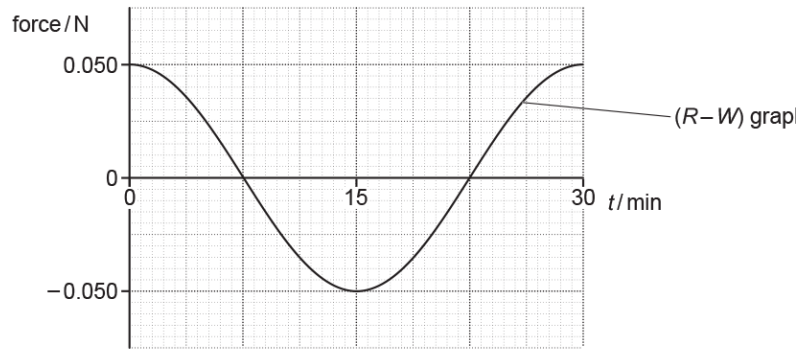

Fig. 6.3

- i. Explain why the horizontal force F between the floor and the tourist is necessary.

[2]

- ii. Draw on **Fig. 6.3** the variation of the horizontal force F during the 30 minutes of the anticlockwise rotation of the London Eye. Take forces to the right to be positive.

[2]

- iii. Calculate the magnitude of force F when the pod is at the position shown in **Fig. 6.2**, at 40° above the horizontal.

$$F = \dots\dots\dots\text{N [2]}$$

- (c). Calculate the distance d of the centre of mass of the tourist from the centre of rotation of the London Eye.

$$d = \dots\dots\dots\text{m [3]}$$

2.1 Physical Quantities

4(a). This question is about a space probe which is in orbit around the Sun.

The space probe has mass 810 kg. The orbital radius of the space probe is 1.5×10^{11} m. The orbital period of the space probe around the Sun is 3.16×10^7 s. The mass of the Sun is 2.0×10^{30} kg.

- i. Show that the magnitude of the gravitational potential energy of the space probe is about 7×10^{11} J.

[2]

- ii. Show that the kinetic energy of the space probe is half the value of your answer to (i).

[3]

- iii. Calculate the total energy of the space probe.

total energy = J[1]

(b). The power source for the instrumentation on board the space probe is plutonium-238, which provides 470 W initially.

Plutonium-238 decays by α -particle emission with a half-life of 88 years. The kinetic energy of each α -particle is 8.8×10^{-13} J.

- i. Calculate the number N of plutonium-238 nuclei needed to provide the power of 470 W.

ii.

$N = \dots\dots\dots$ [3]

- iii. Calculate the power P still available from the plutonium-238 source 100 years later.

2.1 Physical Quantities

$$P = \dots\dots\dots W \text{ [3]}$$

5. This question is about an electric cooker, which consists of an oven and an electromagnetic induction hob.

The oven is not sealed, so the air inside remains at atmospheric pressure of $1.0 \times 10^5 \text{ Pa}$.
The volume of the oven is 0.065 m^3 . The air inside the oven behaves as an ideal gas.

The temperature of the oven increases from room temperature to $200 \text{ }^\circ\text{C}$.

Show that the internal energy of the air in the oven is the same at all temperatures of the oven.
Support your answer with an explanation of the motion of the air molecules in terms of kinetic theory.

[6]

6 (a). Fig. 1 shows a high-speed electric train.

2.1 Physical Quantities

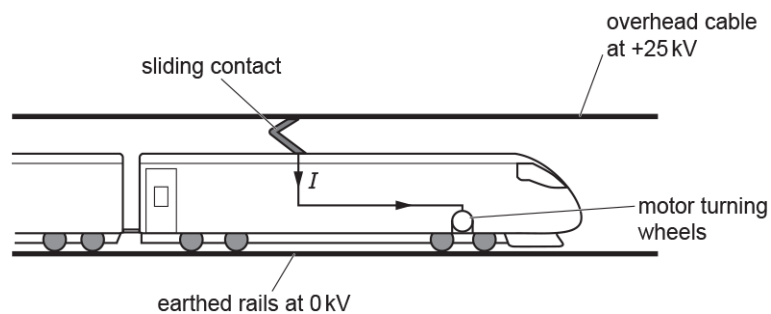

Fig. 1

The potential difference between the overhead cable and the rails on the ground is 25 kV. The sliding contact on the top of the train constantly touches the overhead cable. The overhead cable supplies a current I to the electric motor of the train. The motor turns the wheels. The train experiences a **resultant** forward force F .

The total mass of the train is 2.1×10^5 kg.

The train accelerates from rest. The value of F is 190 kN for speeds less than 6.0 m s^{-1} .

- i. Show that the train's acceleration is about 1 m s^{-2} .

[1]

- ii. Calculate the distance s that the train travels to reach a speed of 6.0 m s^{-1} .

$s = \dots\dots\dots \text{ m}$ [2]

- iii. The speed of the train is v . During one period of its journey, the train accelerates from $v = 30 \text{ m s}^{-1}$ to $v = 60 \text{ m s}^{-1}$. The graph of F against v for this period is shown below.

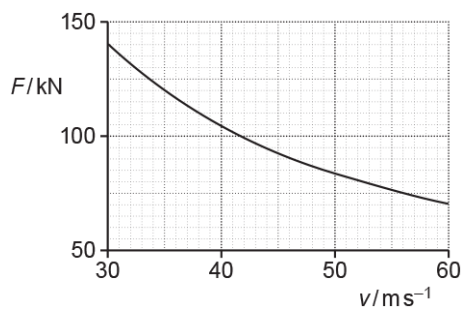

2.1 Physical Quantities

1. Use the graph to show that output power of the electric motor during this period is constant at about 4 MW.

[3]

2. Calculate the current I in the electric motor when the train is travelling at 50 m s^{-1} .

$I = \dots\dots\dots \text{ A}[2]$

2.1 Physical Quantities

(b). The overhead cable in **Fig. 1** must be tensioned. It is constructed from several equal lengths of wire.

Some data for one length of this wire are shown below.

- length = 1500 m
- area of cross-section = $1.1 \times 10^{-4} \text{ m}^2$
- resistivity = $1.8 \times 10^{-8} \Omega\text{m}$
- the Young modulus = $1.2 \times 10^{10}\text{Pa}$
- strain = 1.3%

i. Calculate the resistance R of one length of wire.

$R = \dots\dots\dots \Omega$ [2]

ii. Calculate the tension T in one length of wire.

$T = \dots\dots\dots \text{N}$ [3]

2.1 Physical Quantities

7. This question is about a light-dependent resistor (LDR).

A student connects a potential divider circuit as shown below. It contains an LDR.

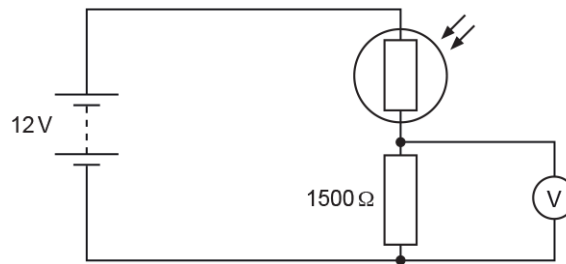

The fixed resistor has resistance 1500Ω .

The battery has electromotive force (e.m.f.) 12 V and negligible internal resistance.

The voltmeter has extremely high resistance.

- i. When the LDR is covered, its resistance is 3000Ω .

Calculate the voltmeter reading.

= V [2]

- ii. When fully illuminated, the resistance of the LDR is 100Ω .
Show that the voltmeter reading **changes** by more than 7 V .

[1]

8. Some lasers are used in eye surgery.

One such laser emits a beam of light of wavelength 490 nm and power 230 mW .

Calculate

- i. the energy of each photon of light from the laser.

energy = J [2]

2.1 Physical Quantities

- ii. the number of photons of light emitted in each second.

number of photons = [2]

9. Which pair of quantities have the same S.I. base units?

- A force, energy
- B moment, momentum
- C power, work done
- D work done, moment

Your answer

[1]

10. The Planck constant h is an important fundamental constant in quantum physics.

Determine the S.I. base units for h .

base units = [2]

11. A sound wave is incident at the ear.

The amplitude of the sound wave is 7.8 nm. The intensity of the sound at the earhole is $4.8 \times 10^{-7} \text{ W m}^{-2}$.

- i. Determine the power of the sound incident at the earhole by estimating the diameter of the earhole in mm.

diameter of earhole \approx mm

power = W [2]

- ii. A different sound wave is now incident at the ear.
The intensity of this wave is $9.6 \times 10^{-7} \text{ W m}^{-2}$.

Calculate the amplitude A in nm of this sound wave.

2.1 Physical Quantities

$A = \dots\dots\dots \text{ nm}$ [2]

12. An athlete is running at a speed of about 5 m s^{-1} .

What is a reasonable estimate for the kinetic energy of this athlete?

- A 12 J
- B 100 J
- C 900 J
- D 800 000 J

Your answer

[1]

13. A student is designing a three-legged wooden stool as shown in Fig. 2.2.

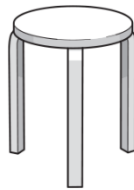

Fig. 2.2

The stool must be able to support the weight of an adult.
The maximum compressive stress of the wood is 2.3 MPa .

Estimate the minimum cross-sectional area A of **one** leg.

$A = \dots\dots\dots \text{ m}^2$ [3]

14. Which definition is correct and uses only quantities rather than units?

- A Acceleration is the change in velocity per second.
- B Resistance is potential difference per ampere.
- C Intensity is energy per unit cross-sectional area.
- D Electromotive force is energy transferred per unit charge.

Your answer

[1]

2.1 Physical Quantities

15. A ball, initially at rest, is struck by a hockey stick. It leaves the hockey stick at speed v .

Which quantity, together with the mass of the ball, can be used to determine v ?

- A The time of the impact.
- B The weight of the hockey stick.
- C The impulse of the force.
- D The final momentum of the hockey stick.

Your answer

[1]

16. The unit of potential difference is the volt.

Use the equation $W = VQ$ to show that the volt may be written in base units as $\text{kg m}^2 \text{A}^{-1} \text{s}^{-3}$.

17. A chemical cell is connected across a resistor.

[3]

- i. The terms electromotive force (e.m.f.) and potential difference (p.d.) are terms associated with the circuit.

State **one** similarity and **one** difference between e.m.f. and p.d.

similarity:

difference:

[2]

- ii. The resistor is cylindrical in shape. It has cross-sectional area $1.2 \times 10^{-6} \text{ m}^2$ and length $6.0 \times 10^{-3} \text{ m}$. In this resistor there are 9.6×10^{16} free electrons. Calculate the mean drift velocity v of the electrons when the current in the resistor is 3.0 mA.

2.1 Physical Quantities

$$v = \dots\dots\dots \text{ m s}^{-1} \text{ [3]}$$

2.1 Physical Quantities

18 (a). A cylindrical cup of internal diameter 7.0 cm and height 8.5 cm is filled to the top with water.

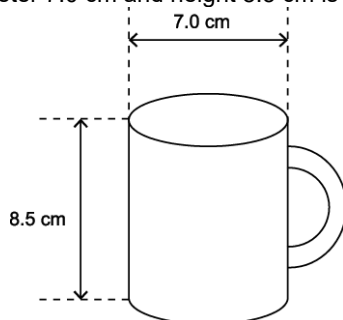

The density of water is 1000 kg m^{-3} . The mass of one mole of water is 18 g. The specific heat capacity of water is $4200 \text{ J kg}^{-1} \text{ K}^{-1}$.

Show that the minimum time taken for a 0.50 kW camping kettle to bring a cup of water at 20°C to boiling point is about 200 s.

[3]

(b). In a laboratory test, the camping kettle was found to bring a cup of water to the boil in 320 seconds.

Explain why your previous answer is an underestimate and suggest **two** ways that you can refine the test to ensure that the time to boil is closer to 200 s.

[3]

END OF QUESTION PAPER